

Nextreme Series Liquid Cooling System

The Nextreme NRC1200 Recirculating Chiller Recirculating Chiller features premium components and environmentally friendly refrigerants in a user-friendly design. It is designed to cool well below ambient and dissipate heat away from thermally sensitive equipment. Featuring variable speed motors for the compressor and condensing fan, the Nextreme NRC1200 offers a high coefficient of performance and low-noise operation. The Nextreme NRC1200 comes with several standard features and additional options allow for application-specific configurations.

Features

- Reliable Performance
- Environmentally Friendly
- User-Friendly
- Application Specific Configurations

Applications

- Recirculating Chillers for Industrial Lasers
- Precise Temperature Control for Microscopes

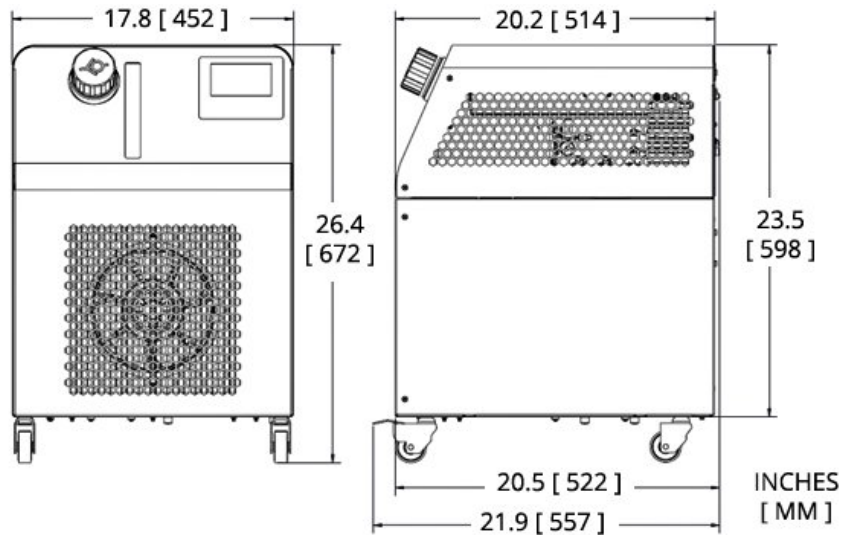
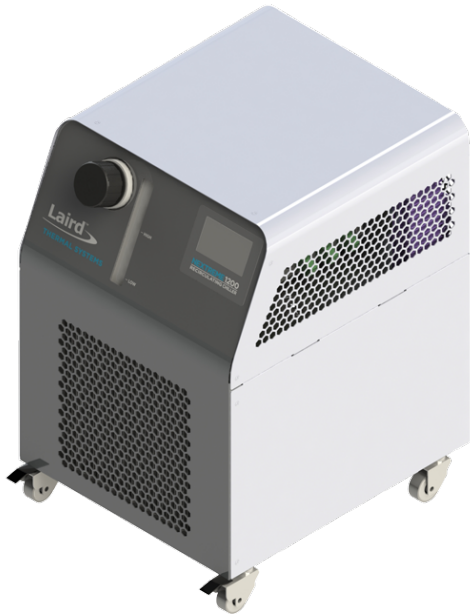

COOLING POWER OPERATING POINTS

100% Water (20°C Ambient Air)

Cooling Power (Qc) = 1800 Watts
Min Fluid Setpoint = 18.6 °C
Fluid ΔT @ 15.0 L/min = 1.7 °C

100% Water (30°C Ambient Air)

Cooling Power (Qc) = 1800 Watts
Min Fluid Setpoint = 24.5 °C
Fluid ΔT @ 15.0 L/min = 1.7 °C

60/40 Water-Glycol (20°C Ambient Air)

Cooling Power (Qc) = 1800 Watts
Min Fluid Setpoint = 19.7 °C
Fluid ΔT @ 15.0 L/min = 1.9 °C

60/40 Water-Glycol (30°C Ambient Air)

Cooling Power (Qc) = 1800 Watts
Min Fluid Setpoint = 25.6 °C
Fluid ΔT @ 15.0 L/min = 1.9 °C

TECHNICAL SPECIFICATIONS

Performance

Cooling Capacity	1,800 Watts
Setpoint Range	-10°C to 40°C
Temperature Stability	±0.1°C
Nominal Operating Flowrate (60 Hz)	15.0 L/min @ 2.6 Bar
Nominal Operating Flowrate (50 Hz)	15.0 L/min @ 1.5 Bar
Refrigerant	R 513A

Operation

Coolant	Water or Water/Glycol
Operating Temperature	15°C to 40°C
Storage temperature range (w/o coolant)	-25°C to 70°C
Humidity range	30% to 80%
Storage Humidity range	5% to 95%, non-condensing
Altitude	< 2,000 meters
Input Voltage	220 - 230 VAC
Frequency	50/60 Hz
Maximum Forward Pressure	4.1 Bar

Physical

Height	670 mm
Length	520 mm
Width	450 mm
Weight	48 kg
Coolant Capacity	5 Liters
Couplings	1/2 in NPT

STANDARD FEATURES

Variable Speed Motors	<i>Variable speed compressor and condensing fans for quiet operation and improved energy efficiency.</i>
Semi-Closed Fluid System	<i>Sealed fluid system with breathable reservoir cap (similar to an automobile). This prevents evaporative losses, introduction of bacteria, and the need for components to prevent fluid from draining back into the system when installed below the application.</i>
Optical Fluid Level Switch	<i>Fluid level sensing with no moving parts.</i>
RS-232 / RS-485 Communications	<i>Complete control integration of chiller into higher level assembly control system.</i>
Supply Pressure Sensing	<i>Pressure sensing for applications sensitive to high operating conditions.</i>

OPTIONAL FEATURES

Feature	Option Code	Description
Flow Control Valve and Flow Sensing Kit F		<i>Externally installed valve for reducing the overall flow to the application. Full flow continues through the chiller to maintain high heat transfer rates and temperature stability. Flow meter for measuring coolant flow rate. Installed external to the chiller with both a local display and connectivity to chiller LCD display.</i>
Water Filter Kit	W	<i>Hot swappable, 5-micron water filter for filtering particulates from the coolant circuit.</i>

NOTES

1. System option codes are added to the end of the model number in alphabetical order.

Any information furnished by Laird and its agents, whether in specifications, data sheets, product catalogues or otherwise, is believed to be (but is not warranted as being) accurate and reliable, is provided for information only and does not form part of any contract with Laird. All specifications are subject to change without notice. Laird assumes no responsibility and disclaims all liability for losses or damages resulting from use of or reliance on this information. All Laird products are sold subject to the Laird Terms and Conditions of sale (including Laird's limited warranty) in effect from time to time, a copy of which will be furnished upon request.

© Copyright 2020 Laird Thermal Systems GmbH. All Rights Reserved. Laird, Laird Technologies, Laird Thermal Systems, the Laird Logo, and other word marks and logos are trademarks or registered trademarks of Laird Limited or an affiliate company thereof. Other product or service names may be the property of third parties. Nothing herein provides a license under any Laird or any third party intellectual property rights.

Date: 05/19/2020